

Ethernet

ITS323: Introduction to Data Communications
CSS331: Fundamentals of Data Communications

Sirindhorn International Institute of Technology
Thammasat University

Prepared by Steven Gordon on 13 October 2015
ITS323Y15S1L12, Steve/Courses/2015/s1/its323/lectures/ethernet.tex, r4135

Contents

IEEE 802 LANs

Switched Ethernet

Ethernet Frames and Addressing

IEEE 802 LAN Architecture

- ▶ Institute of Electrical and Electronics Engineers: professional and standards organisation
 - ▶ 754 (Floating Point Arithmetic), 828, 829, 830, (Software Development), 1003 (POSIX), 1076 (VHDL), 1363 (Cryptography), 1394 (Firewire), ...
- ▶ IEEE 802: LAN/MAN standards committee
 - ▶ Developing standards for PANs, LANs, MANs, WANs
 - ▶ Divided into numbered working groups
- ▶ IEEE 802 standards focus on:
 - ▶ Physical (PHY) layer
 - ▶ Data link (DL) layer
 - ▶ Medium Access Control (MAC): efficient data transfer, sharing the medium
 - ▶ Logical Link Control (LLC): addressing, connecting to other networks
- ▶ IEEE 802.3 (Ethernet), IEEE 802.5 (Token Ring), IEEE 802.11 (WiFi), IEEE 802.15.1 (Bluetooth), IEEE 802.16 (WiMax), ...

IEEE 802 LAN Architecture

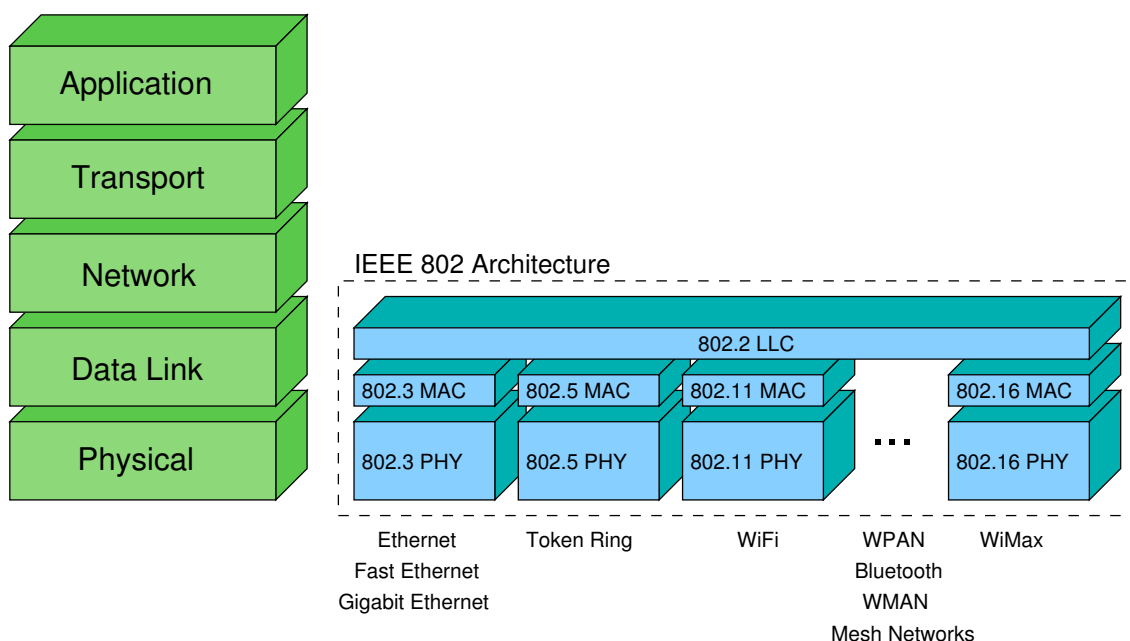

LLC = Logical Link Control
 MAC = Medium Access Control
 PHY = Physical

IEEE 802.3: Ethernet

- ▶ Ethernet developed for LAN communications in 1970's; standardised as IEEE 802.3 in 1983
- ▶ Several competing technologies at the time: Token Ring, Token Bus
- ▶ Ethernet became most popular and now most common LAN standard
- ▶ Evolution of Ethernet:
 - ▶ Ethernet ('73): 3 Mb/s, coaxial cable, bus topology, half-duplex, shared medium
 - ▶ Ethernet II ('83): 10 Mb/s
 - ▶ Fast Ethernet ('87): 100 Mb/s, twisted pair, star topology with hub
 - ▶ Switched Ethernet ('90): 100 Mb/s, full duplex, star topology with switch, point-to-point links
 - ▶ Gigabit Ethernet ('99): 1 Gb/s, twisted pair or optical fibre
 - ▶ For data centres, MANs and WANs: 10 Gb/s, 40 Gb/s, 100 Gb/s, 400 Gb/s

5

Contents

IEEE 802 LANs

Switched Ethernet

Ethernet Frames and Addressing

6

Switched Ethernet

- ▶ Most LANs today use Ethernet in a star topology
- ▶ Centre device is called switch (different from a hub)
- ▶ Key characteristics of today's LANs:
 - ▶ Stations have full-duplex, point-to-point links to switch
 - ▶ Twisted pair cable (Category 5 UTP)
 - ▶ Data rate: 100 Mb/s or 1 Gb/s (auto-negotiation)
 - ▶ PHY standard: 802.3u (100BASE-TX) or 802.3ab (1000BASE-T)
 - ▶ Distance: 100 m
 - ▶ Random access is *not* used

7

Switched Ethernet Topology

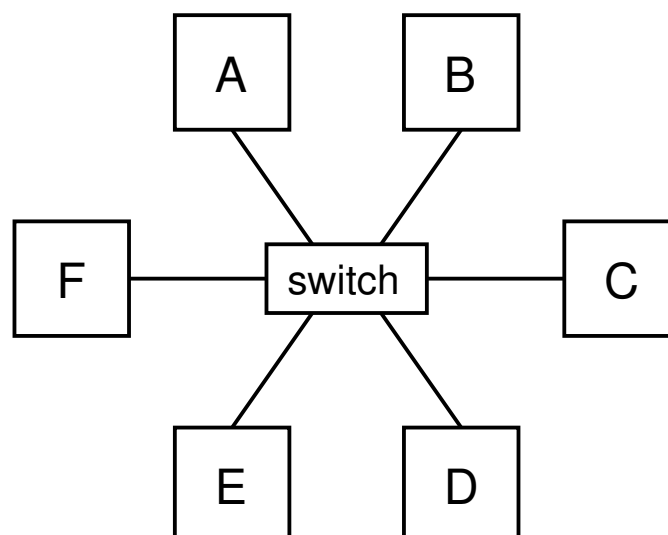

- ▶ Stations (hosts, routers) connect via full-duplex twisted pair to switch
- ▶ Switch has multiple ports, e.g. 4, 8, 24, 48
- ▶ All frames between stations pass via the switch

8

IEEE 802 LANs

Switched Ethernet

Ethernet Frames and Addressing

9

IEEE 802 Addresses

- ▶ IEEE 802 standards use common IEEE 48-bit address format
- ▶ Commonly called MAC or hardware addresses
- ▶ Globally unique (ideally)
 - ▶ First 24-bits assigned by IEEE to manufacturer
<http://standards.ieee.org/regauth/oui/>
 - ▶ Second 24-bits assigned by manufacturer to device
- ▶ For simplicity, represented as 6 × 2 digit hexadecimal numbers, e.g. 90:2b:34:60:dc:2f
- ▶ Special case broadcast address: ff:ff:ff:ff:ff:ff
- ▶ Common in other standards: Bluetooth, ATM, FDDI, FibreChannel
- ▶ IEEE 64-bit address is alternative format: Firewire, ZigBee, IPv6

IEEE 802.3 Frames

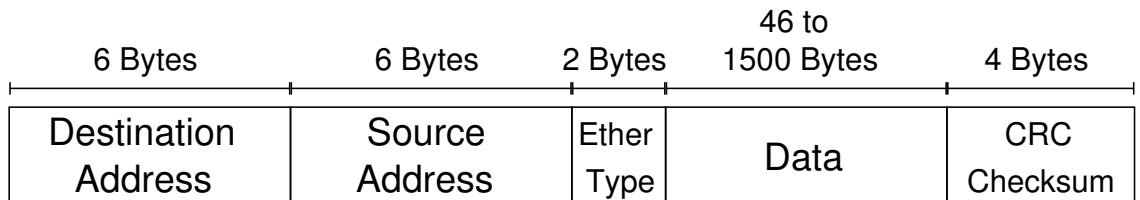

- ▶ Typical maximum data size is 1500 Bytes (optional Jumbo frames)
- ▶ 1st 8 bytes (preamble, delimiter) sometimes considered part of Physical layer

Example Hardware Addresses

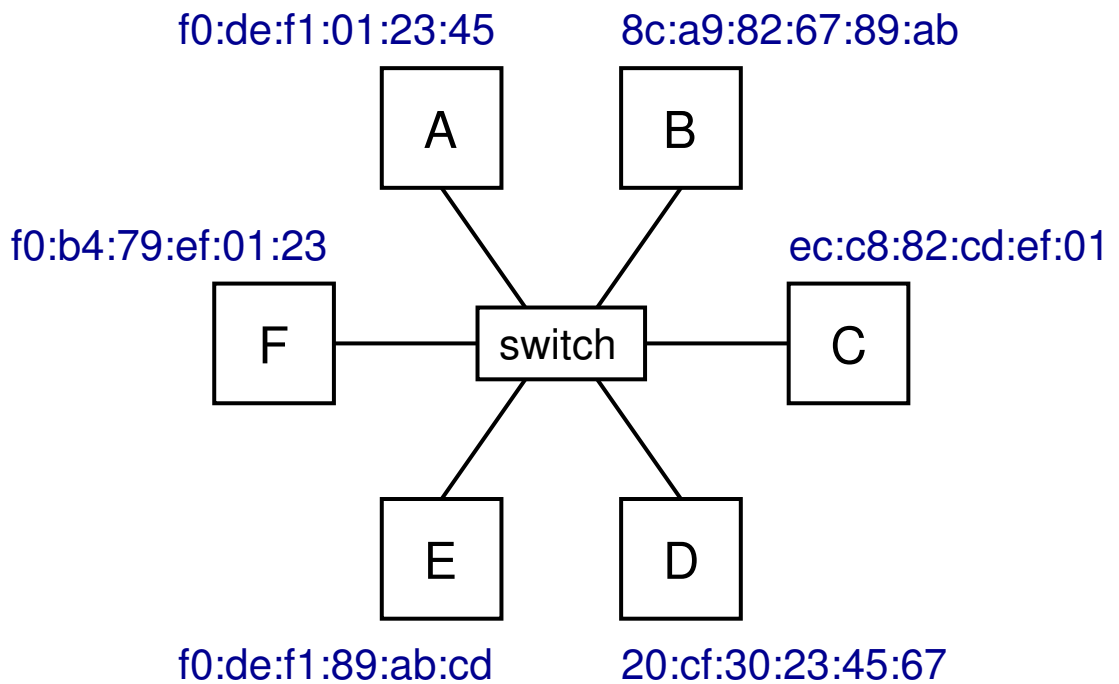

- ▶ Hardware (MAC) addresses are assigned to LAN card by manufacturer
- ▶ Each station (hosts and routers) has address for each network interface card

Example MAC Table used by Switch

Ethernet

IEEE 802

Switched Ethernet

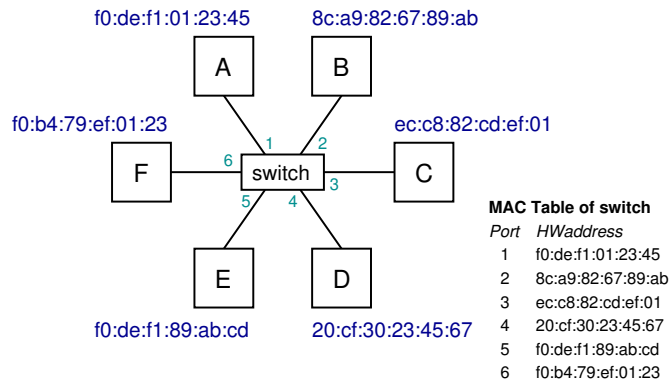
Frames &
Addresses

- ▶ Switch learns address of station at other end point of link
- ▶ Store address and port in memory; used for forwarding frames