

Data rate: 1 Mb/s
Payload: 1000 B
Header/ACK: 50 B
Speed of light: 3×10^8 m/s

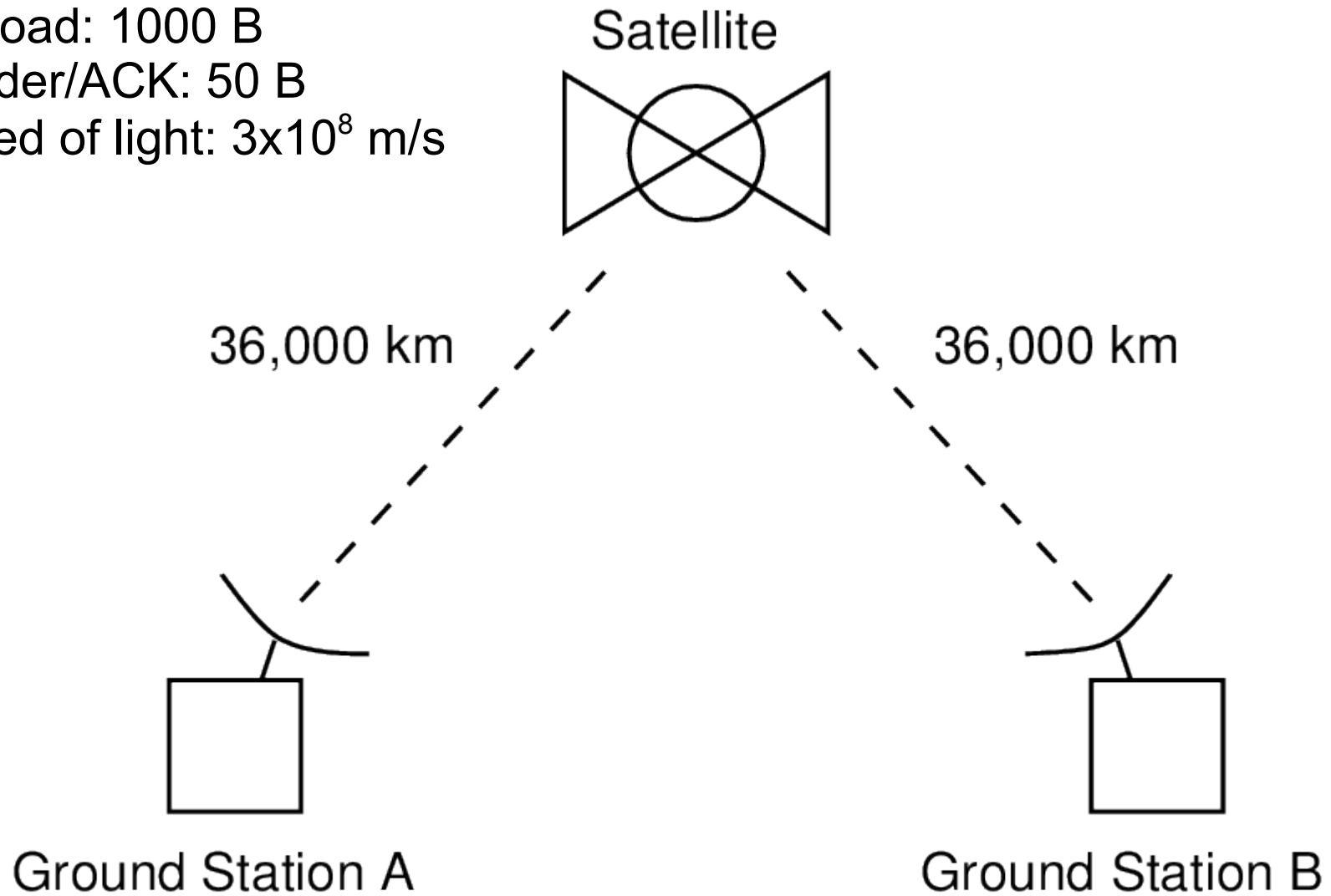

Propagation delay: $36,000 \text{ km} @ 3 \times 10^8 \text{ m/s} = 120 \text{ ms}$

DATA transmission delay: $1050 \text{ B} @ 1 \text{ Mb/s} = 8.4 \text{ ms}$

ACK transmission delay: $50 \text{ B} @ 1 \text{ Mb/s} = 0.4 \text{ ms}$

Stop and Wait (Window = 1)

Time to receive ACK: $8.4 + 120 + 0.4 + 120 = 248.8 \text{ ms}$

Real data delivered: 1000 B

Throughput: $1000 \text{ B} / 248.8 \text{ ms} = 32,154 \text{ b/s}$

Efficiency: $32,154 \text{ b/s}$ out of $1 \text{ Mb/s} = 3.2 \%$

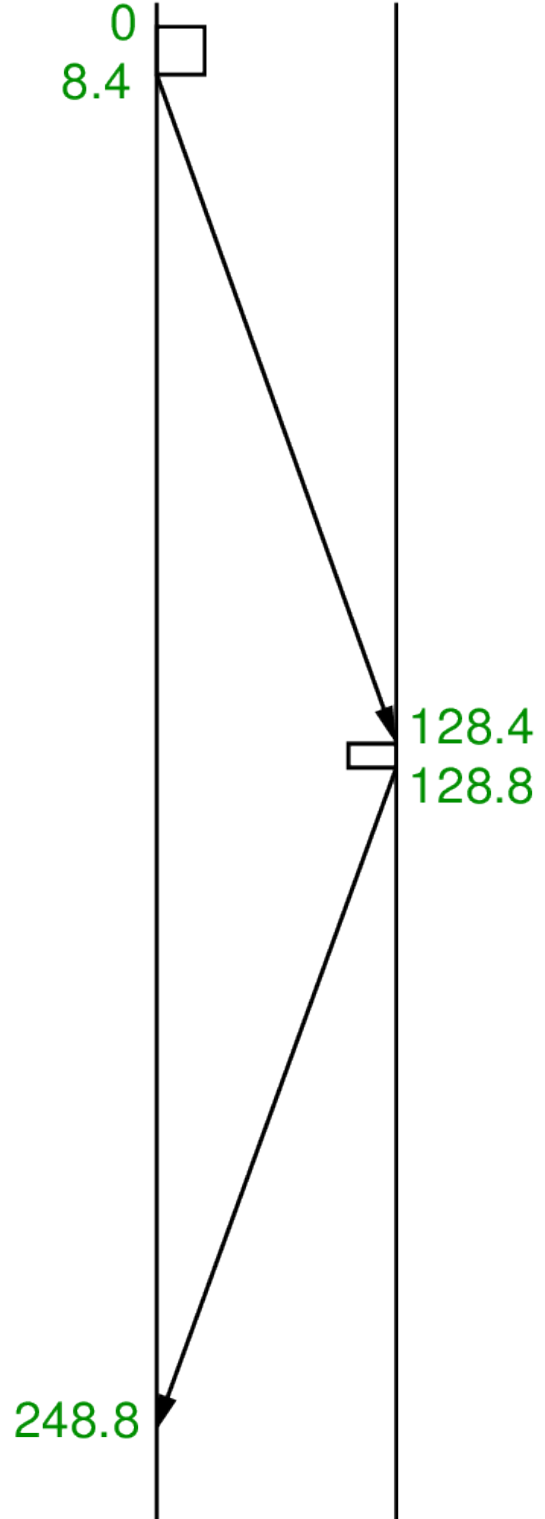

Propagation delay: $36,000 \text{ km} @ 3 \times 10^8 \text{ m/s} = 120 \text{ ms}$

DATA transmission delay: $1050 \text{ B} @ 1 \text{ Mb/s} = 8.4 \text{ ms}$

ACK transmission delay: $50 \text{ B} @ 1 \text{ Mb/s} = 0.4 \text{ ms}$

Sliding Window (Window = 7)

Time to receive ACK: $8.4 + 120 + 0.4 + 120 = 248.8 \text{ ms}$

Time to send window of frames: $7 \times 8.4 = 58.8 \text{ ms}$

Real data delivered: 7000 B

Throughput: $7000 \text{ B} / 248.8 \text{ ms} = 225,080 \text{ b/s}$

Efficiency: $225,080 \text{ b/s}$ out of $1 \text{ Mb/s} = 22.5 \%$

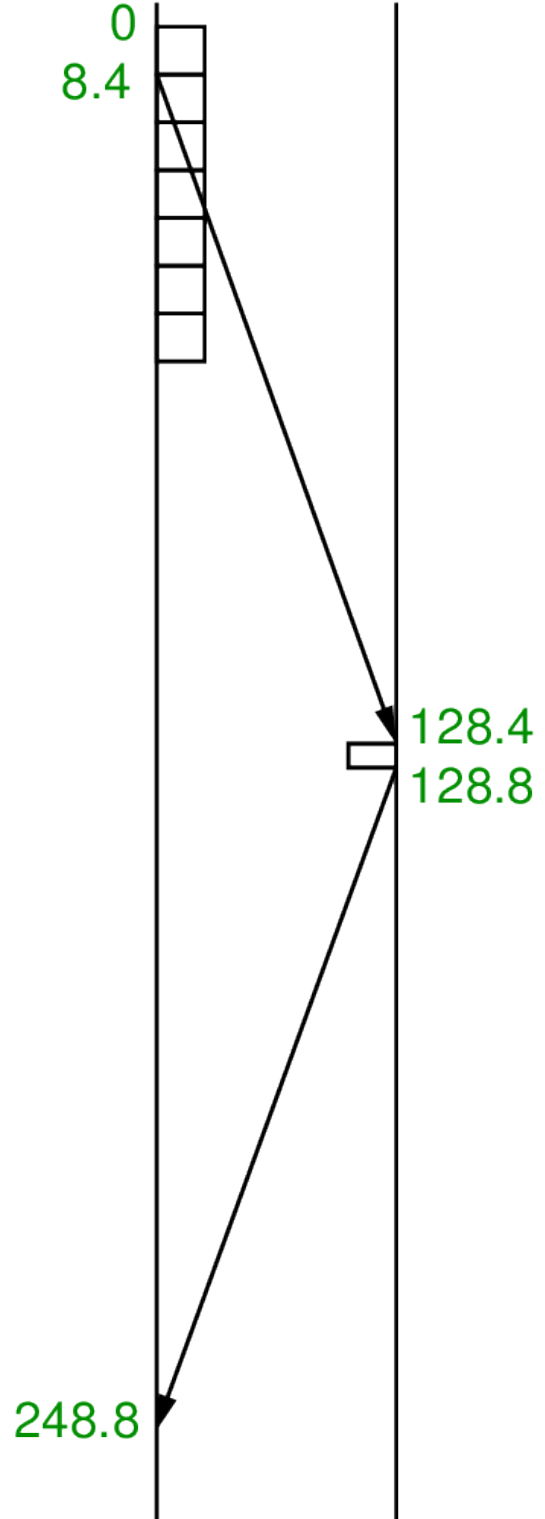

What size window to achieve highest efficiency?

Time to receive ACK: 248.8 ms

DATA Transmission delay: 8.4 ms

Aim: continuously send DATA frames (no waiting)

DATA frames in time to receive ACK: $248.8 / 8.4 = 29.6$

Window size of 30 frames is sufficient

With 5 bit sequence number, maximum window size is 31 frames

$W = 31$:

Efficiency: $1000 \text{ B} / 1050 \text{ B} = 95.2 \%$

Throughput: 952,381 b/s

